

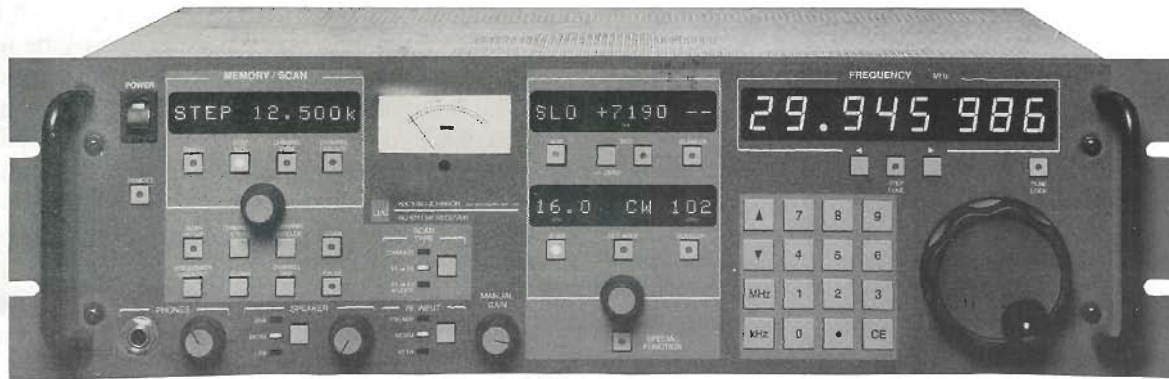

Digital HF Receiver WJ-8711



Description

The WJ-8711 is a fully synthesized, general-purpose HF receiver for surveillance and monitoring of RF communications from 5 kHz to 30 MHz with 1-Hz tuning resolution. By combining analog and digital signal processing (DSP), the WJ-8711 achieves high performance at low cost.

Functions such as noise blanking, IF filtering, AGC, demodulation, Beat Frequency Oscillator (BFO) and passband tuning are accomplished through the use of DSP techniques. Filters with superior amplitude and group delay characteristics are achieved with digital stability and repeatability. Standard selectable IF bandwidths are 0.3, 1.0, 3.2, 6.0 and 16.0 kHz. Available detection modes are AM, FM, CW, USB, LSB and ISB. A tunable BFO can be adjusted in 10-Hz steps over a ± 8000 Hz range, and passband tuning is available to further enhance the reception of CW signals. Gain control can be accomplished manually or automatically, with fast and slow AGC modes available. The squelch threshold is adjustable from 0 to -135 dBm, or it can be disabled. A noise blanking feature can also be enabled to effectively eliminate the adverse effects of impulsive noise.

In addition to fixed-frequency tuning, the WJ-8711 provides a fast, flexible scanning capability. Three scan modes are available: channel scan, F1-F2 scan and F1-F2 scan with lockouts. For all scan modes, the dwell time can be set from 0.5 to 20 seconds or infinite. In channel scan mode,

Features

- Frequency coverage from 5 kHz to 30 MHz in 1-Hz steps
- High dynamic range: +30 dBm 3rd-order intercept typical
- Digital filtering provides 5 or more IF bandwidths up to 16 kHz with exceptional shape factors.
- AM, FM, CW, USB, LSB & ISB Detection Modes Standard
- Fast, flexible scanning with 100 memory channels
- Large readable LED displays & user-friendly controls
- Noise blanking & passband tuning
- Internal switchable preamplifier & Attenuator
- Operator-Selectable RS-232 or CSMA remote control
- Built-in self test
- Optional Suboctave Preselector
- Optional Digital Data Output

For Further Information Please Contact:

WATKINS-JOHNSON
Company
700
(301)
Print



Luftmaterieel A/S
Postboks 534 Sentrum
0105 Oslo, 1
Tlf. (02) 42 25 40

20878-1794
FAX: (301) 921-9479

March 1993

Supersedes Technical Data Sheet
192.00 dated March 1992

Specifications subject to change without notice.

100 programmable memory channels are available. Sectors of memory can be specified for individual channel scans, allowing the available memory to be subdivided into multiple search scenarios. The operator can specify certain channels to be skipped without having to delete them from memory. Memory channels can also be single-stepped manually. In both F1-F2 scan modes, the step size is user-selectable from 1 Hz to 25 kHz. Up to 100 independent frequency lockouts can be stored.

The WJ-8711 can be operated locally via the front panel or remotely via one of two selectable serial interfaces. Measuring 5.25 x 19 inches, (13.34 x 48.26 cm), the microprocessor-controlled front panel provides a user-friendly operator interface with dedicated, logically arranged controls and large, easy-to-read LED displays. Figure 1 illustrates the organization of the front panel and highlights some of the features available to the local operator.

A majority of the WJ-8711 operator-selectable parameters are controllable and accessible via an RS-232 remote interface. A Carrier Sense Multiple Access with Collision Detection (CSMA) with a limited instruction set interface may be enabled, in lieu of RS-232, to allow the WJ-8711 to be controlled

using a command protocol similar to several popular consumer receivers. Selection of the active interface is via an internal switch setting or by front panel entry. The factory should be contacted for a detailed list of remote control commands in order to eliminate any confusion over the extent of the available commands included in each type of interface.

All receiver inputs and outputs are available on the rear panel of the unit with the exception of the front-panel-mounted headphone jack. The antenna and external reference inputs, as well as the signal monitor and predetected IF outputs, are available on BNC connectors. Speaker and dual-balanced line audio outputs are available on a terminal strip along with dc-coupled audio, RSSI and squelch outputs, and a mute control input. The RS-232 interface is available on a 25-pin D-shell connector, and the CSMA interface is provided via a miniature phone jack.

The WJ-8711 can be used as a tabletop receiver or mounted in a standard 19-inch (48.26 cm) equipment rack occupying 5.25 inches (13.34 cm) of vertical rack space. The internal power supply accepts 97 to 253 Vac (47 to 63 Hz) line power and automatically adjusts to the input line voltage. Total power consumption of the unit is less than 35 watts.

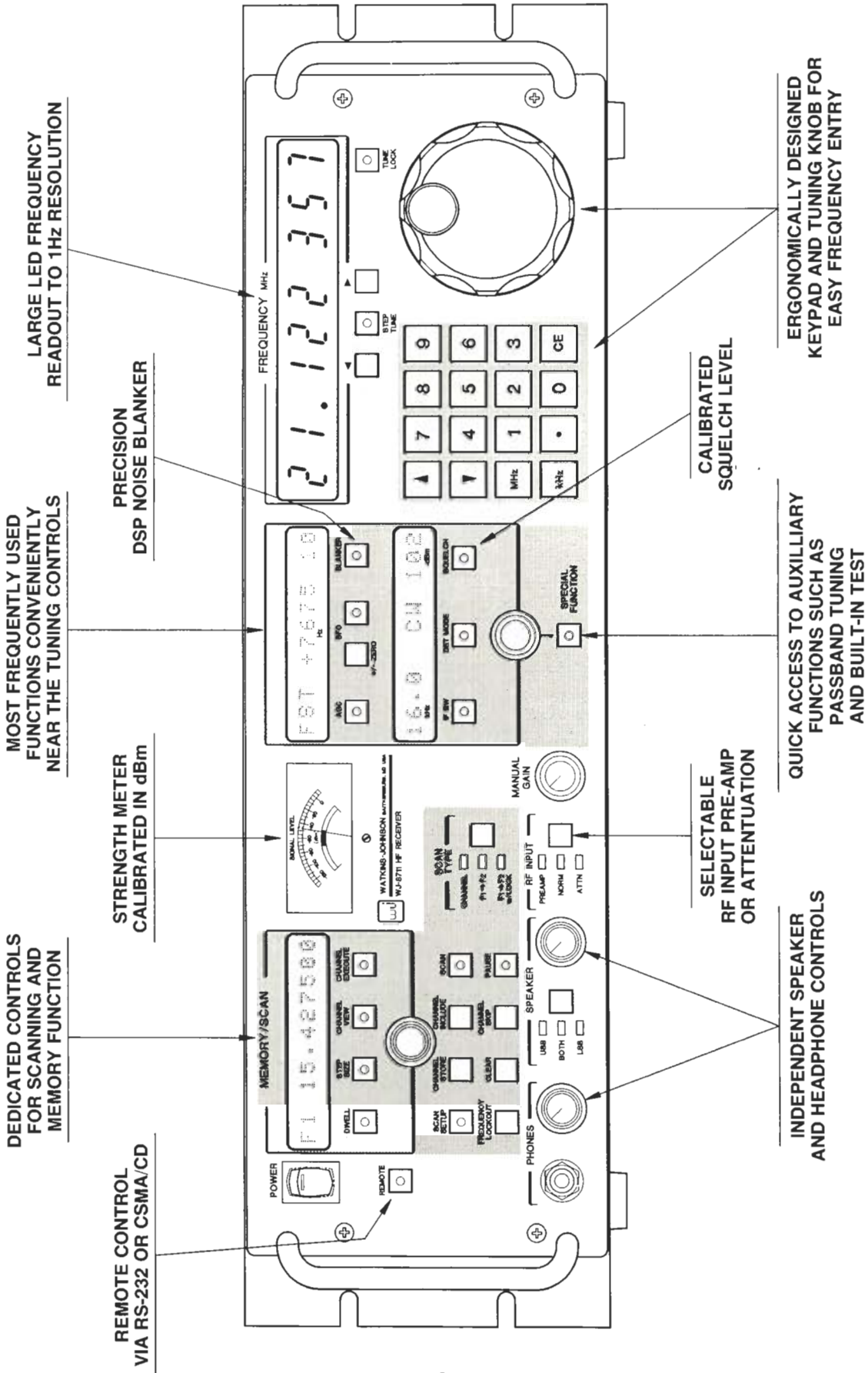

Figure 1. WJ-8711 Front Panel Features

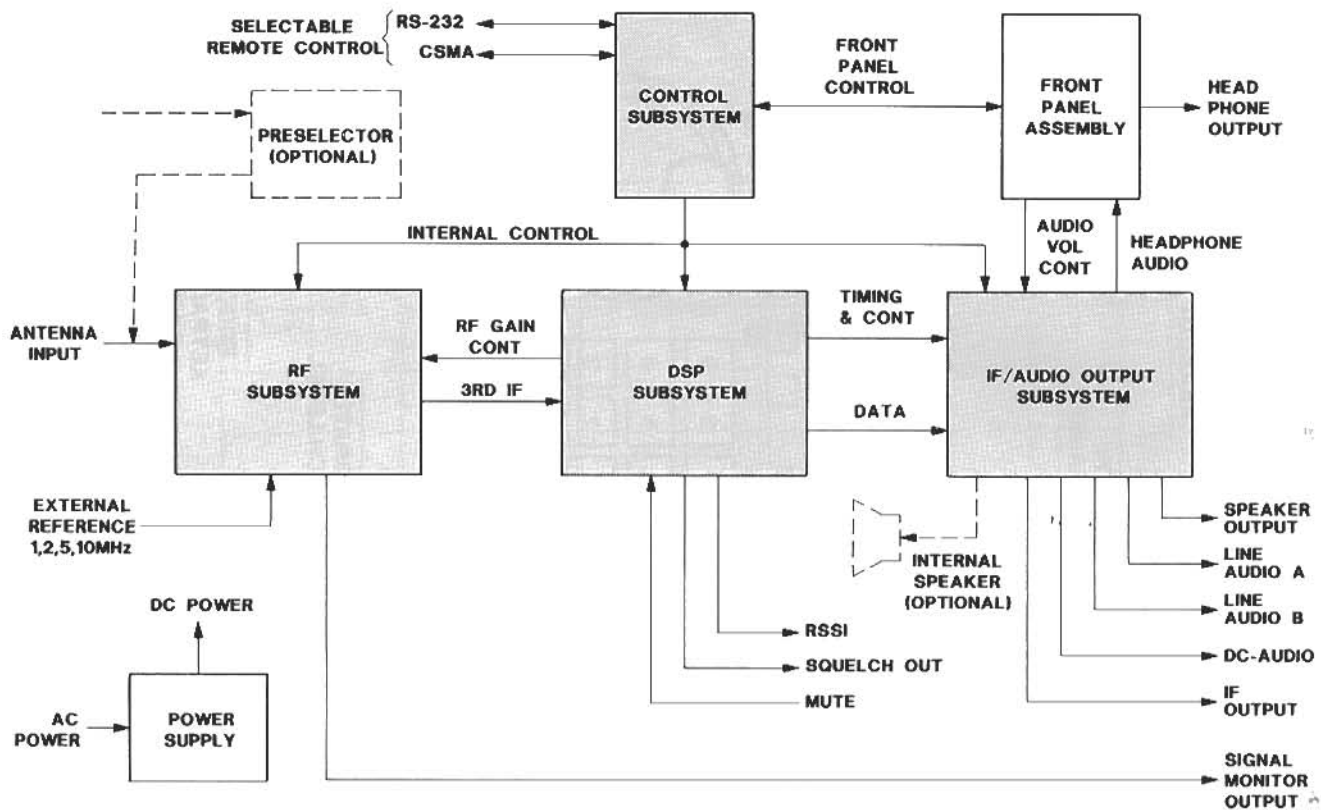

Figure 2. WJ-8711 Functional Block Diagram

Functional Description

As illustrated in Figure 2, the WJ-8711 can be divided into four functional subsystems: RF, DSP, IF/Audio Output and Control. Figure 3 provides a functional block diagram of the RF Subsystem. The 5 kHz to 30 MHz RF signal is applied to the receiver's antenna input, is lowpass filtered, and is then either amplified, attenuated or routed to the normal through-path based on user selection. The signal is then mixed with the first local oscillator (LO), which tunes from 40.455 MHz to 70.455 MHz in 1-kHz steps, to produce a first IF of 40.455 MHz. The first IF filter limits the bandwidths of the signal to approximately 30 kHz before mixing it with the 40-MHz second LO to produce a second IF at 455 kHz. A sample of this second IF is provided on a rear panel for connection

to a signal display unit. After passing through the second IF filter, the signal is mixed with the 430-kHz third LO to produce the third IF centered at 5 kHz.

All LOs are derived from an internal 10-MHz oscillator that can be locked to an external reference input of 1, 2, 5 or 10 MHz. The WJ-8711 automatically senses and switches to the external reference upon application of signal. All critical timing signals used in the DSP and IF/Audio Output Subsystems are also derived from this reference.

The DSP Subsystem performs the majority of the signal processing function within the receiver. The third IF signal from the RF Subsystem is digitized to 16-bits of resolution at a sampling rate of 100 kHz. This digitized IF signal is applied to a programmable

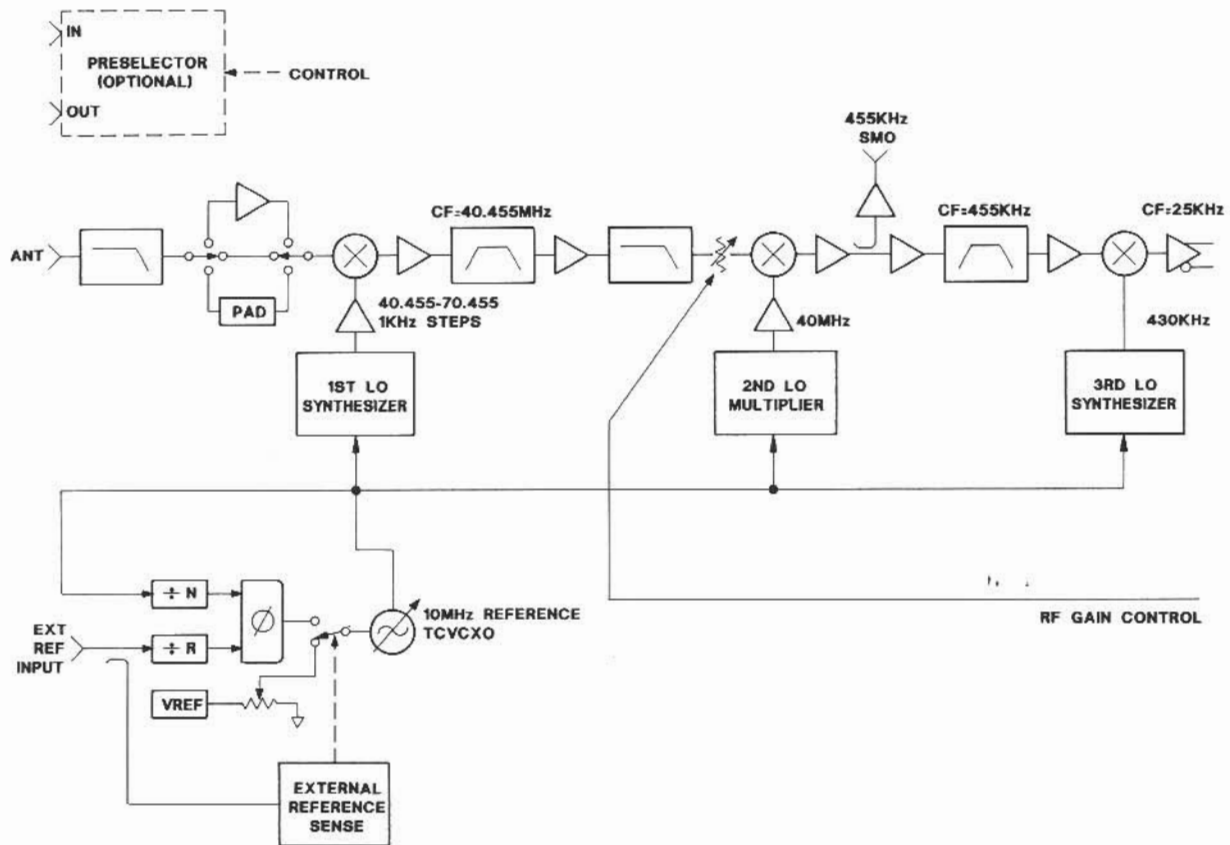

Figure 3. WJ-8711 RF Subsystem Functional Block Diagram

DSP chip that performs the following functions based on operator selection of the receiver's parameters:

- Noise blanking
- Fine tuning to 1-Hz resolution
- IF filtering
- Gain control (AGC Fast, AGC Slow or Manual)
- Signal strength & squelch functions
- Signal demodulation & BFO
- Generation of a multiplexed Digital Data Stream containing 1 or 2 demodulated Audio Channels & a post-filtered IF signal

The IF/Audio Output Subsystem performs the analog reconstruction of the IF and audio signals provided by the DSP Subsystem in digital form. The analog audio signals are routed through two distinct signal paths to accommodate ISB detection mode. In all other

detection modes, both paths contain identical audio signals. These two audio paths are processed to provide a two-channel headphone output, two balanced 600-ohm line audio outputs and an 8-ohm speaker output containing one or both audio channels in ISB mode. After analog reconstruction, the IF signal is upconverted to 455 kHz, passed through a bandpass roofing filter to remove mixer products, buffered and routed to the rear panel IF output connector.

The microprocessor-based Control Subsystem performs the receiver's internal control, acts as an interface with the front panel, and provides a remote control function through either the RS-232 or CSMA interface. The Control Subsystem also monitors hardware status within the receiver and, when commanded, performs a built-in test sequence that isolates circuit faults to the module level.

Specifications

Frequency Range	5 kHz to 30 MHz (tunable to 0 Hz, degraded performance below 500 kHz)
Tuning Resolution	1 Hz
Internal Reference Stability	Better than 0.7 PPM (0 to 50°C) Better than 0.2 PPM (0 to 50°C) with REF option
External Reference Frequency	Accepts 1, 2, 5 or 10 MHz (± 1 PPM or better, 200 mV RMS into high impedance load); automatically switches to external reference upon application of signal
Synthesizer Lock Time	<10 msec, typical
Antenna Input	
Impedance	50 ohms, nominal
VSWR	2:1 maximum at receiver's tuned frequency
Maximum Input Signal	+30 dBm
Connector	BNC, female
3rd-Order Intercept Point	+30 dBm, typical + 25 dBm, minimum (for signals separated by 50 kHz, minimum)
2nd-Order Intercept Point	+60 dBm, typical
Noise Figure	14 dB, maximum (11 dB maximum with preamplifier engaged)
Detection Modes	AM, FM, CW, USB, LSB & ISB (Consult factory for additional demodulation modes)

Sensitivity (500 kHz to 30 MHz)

Modulation	IFBW (kHz)	(Minimum)	Without Preamp Min dBm/(μ V)
		S+N/N (dB)	
AM (50% mod. at 400 Hz)	6.0	10	-103/(1.58)
FM (4.8 kHz dev. 400 Hz mod)	16.0	17	-99/(2.50)
USB/LSB/ISB	3.2	10	-112/(0.56)
CW	0.3	16	-116/(0.35)

CW Sensitivity, 5 to 500 kHz, without Preamp (0.3 kHz IF Bandwidth)

50 to 500 kHz	-113 dBm/0.5 μ V typical for 16 dB S+N/N
20 to 50 kHz	-105 dBm/1.27 μ V typical for 16 dB S+N/N
5 to 20 kHz	-78 dBm/28 μ V typical for 16 dB S+N/N

IF Output

Center Frequency	455 kHz, nominal
Output Level	-20 dBm, nominal
Output Impedance	50 ohms, nominal
Connector Type	BNC, female

Signal Monitor Output

Center Frequency	455 kHz, nominal; inverted
Bandwidth	30 kHz (-6dB), minimum
Output Level	30 dB above RF input, nominal
Output Impedance	50 ohms, nominal
Connector Type	BNC, female

Gain Control Modes	Manual, AGC Fast & Slow
AGC Range	100 dB, minimum
AGC Threshold	Approximately -108 dBm (0.9 μ V) in 16-kHz bandwidth Approximately -125 dBm (0.12 μ V) in 300-Hz bandwidth (Threshold is matched with IF bandwidth & is typically 10 dB above noise floor)
AGC Attack Time	15 msec, typical
AGC Decay Time	Fast: 25 msec, typical Slow: 4 seconds, typical

Selectable Front End Gain/Attenuation

Preamplifier Gain	10 dB (\pm 2 dB)
Attenuation	15 dB (\pm 2 dB)

BFO

Tuning Range	\pm 8000 Hz
Tuning Resolution	10 Hz

First Image Rejection	90 dB, minimum
------------------------------------	----------------

IF Rejection	85 dB, minimum (>90 dB, typical)
---------------------------	----------------------------------

LO Phase Noise (see Figure 7)	-110 dBc at 1-kHz offset, typical
--	-----------------------------------

Reciprocal Mixing	With a desired signal of 25 μ V in the 3.2-kHz IF bandwidth, the desired signal-to-noise ratio (SNR) is greater than 20 dB, when an undesired signal 70-dB higher in amplitude and 35-kHz removed in frequency is present.
--------------------------------	--

Cross Modulation	With a desired signal of 10 μ V, an undesired signal 86-dB higher, 30% AM modulated produces less than 10% cross modulation for frequency separation of >50 kHz in the 1-kHz IF bandwidth.
-------------------------------	--

Internal Spurious	<-114 dBm referred to the RF input
--------------------------------	------------------------------------

Blocking	An unwanted signal 1 mV separated 20 kHz from a desired signal of 1 μ V will not cause the IF output to fall by more than 3 dB.
-----------------------	---

Line Audio Outputs

Number of Outputs	Two center-tapped, balanced outputs. For ISB mode, USB & LSB on separate outputs. For all other modes, audio signal is common to both outputs.
Output Level	0 dBm, nominal into 600-ohm load
Connector Type	Screw terminals

Speaker Output

Number of Outputs	One output. For ISB mode, USB & LSB can be selected individually or combined. (Internal speaker optional).
Bandwidth	100 Hz to 13 kHz
Output Level	Adjustable up to 1 W into 8-ohm load
Total Harmonic Distortion	<3% at 1 W
Connector Type	Screw terminals

Headphone Output

Number of Outputs	Two unbalanced outputs. For ISB mode, one output contains USB (left channel), the other contains LSB (right channel). In all other modes, the audio signal is common to both outputs.
Output Level	Adjustable up to 10 mW into 600-ohm load
Connector Type	Standard 1/4 in. stereo jack

Remote Control	RS-232 or CSMA; selectable by internal switch or front panel entry
RS-232	Full duplex, 3-wire serial interface; rear panel 25-pin female D-shell connector
CSMA	Half duplex, rear panel miniature phone jack
Baud Rates	75, 150, 300, 600, 1200, 2400, 4800 & 9600;
(Both Interfaces)	selectable by internal switches or front panel entry

Environmental Specifications

MIL-STD-810D Test Method

- A. Low Temperature Test Method 502.2
- B. High Temperature Test Method 501.2
- C. Humidity Test Method 507.2
- D. Altitude Test Method 500.2
- E. Vibration Test Method 514.3
- F. Shock Test Method 516.3

Operating Temperature	0 to +50°C
Storage Temperature	-40 to +70°C
Humidity	10 cyclic days (240 hours); Procedure III for continuous exposure to 95% RH
Altitude	50,000 ft. (15,240 meters) non-operating 24,000 ft. (7,315 meters) operating

Vibration⁽¹⁾

- A. Basic Transportation (secure cargo)
Category 1 random vibration 1.04Gs non-operating (2 hours)
- B. Ground mobile (wheeled or tracked vehicle) Category 8 random vibration 6.0Gs operating (15 minutes)
- C. Marine (shipboard vessel not specified) Category 9 random vibration 1.0Gs operating (2 hours)
- D. Environmental stress (NAVMAT-P-9492) random vibration 6.0Gs operating (15 minutes for design qualifications) 3.06Gs nonoperating [10 minutes for production screening (ESS)]

Shock⁽¹⁾	Bench handling (field service) 8 drops total onto a horizontal hard wooden surface, operatin
----------------------------------	--

MTBF	In excess of 14,000 hours; estimated in accordance with MIL-HDBK 217E for Ground Fixed; +40°C environment
-------------------	---

Power Requirements	97 to 253 Vac (47 to 440 Hz)
---------------------------------	------------------------------

Power Consumption	35 W typical with options
--------------------------------	---------------------------

Weights & Dimensions

Height	Width	Depth	Weight
5.25 in. (13.36 cm)	19.0 in. (48.26 cm)	20.0 in. (50.80 cm)	15 lbs. (6.78 kg)

Table 1. IF Filter Specifications*

3-dB Bandwidth (kHz)**	(Maximum) Shape Factor (3/60 dB)	(Typical) Group Delay Variation (100% of 3-dB Bandwidth)
0.3	1.35:1	50 μ S
1.0	1.40:1	30 μ S
3.2	1.25:1	30 μ S
6.0	1.25:1	40 μ S
16.0	1.25:1	60 μ S
USB/LSB/ISB (3.2)	1.25:1	30 μ S

* See typical plots in Figure 4, 5 & 6

** Consult factory for alternate or additional IF bandwidths

Table 2. Connectors (Inputs/Outputs)

I/O	Function	Type
Input	Antenna External Reference Power Mute	BNC BNC IEC 3-pin Terminal Block
Output	Signal Monitor IF Line Audio Output A Line Audio Output B Speaker DC-coupled Audio Squelch Headphone Received Signal Strength Indicator	BNC BNC Terminal Block Terminal Block Terminal Block Terminal Block Terminal Block Standard 1/4 in. stereo jack Terminal Block
Both	CSMA Remote Interface RS-232 Remote Interface	1/8th in. miniature stereo jack 25-pin female D-shell

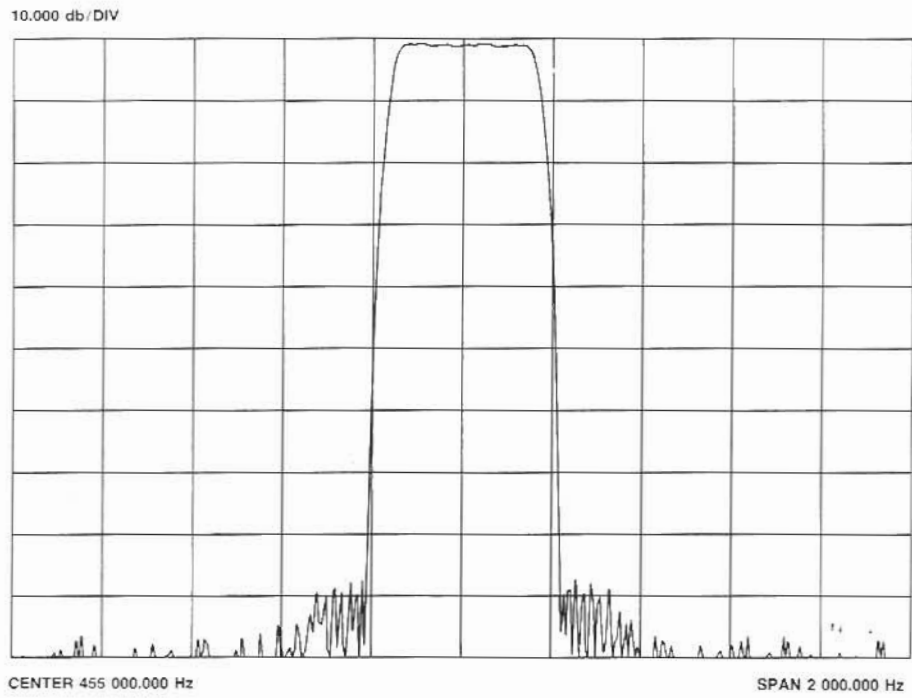

Figure 4. WJ-8711 Typical 300 Hz IF Filter Amplitude Response

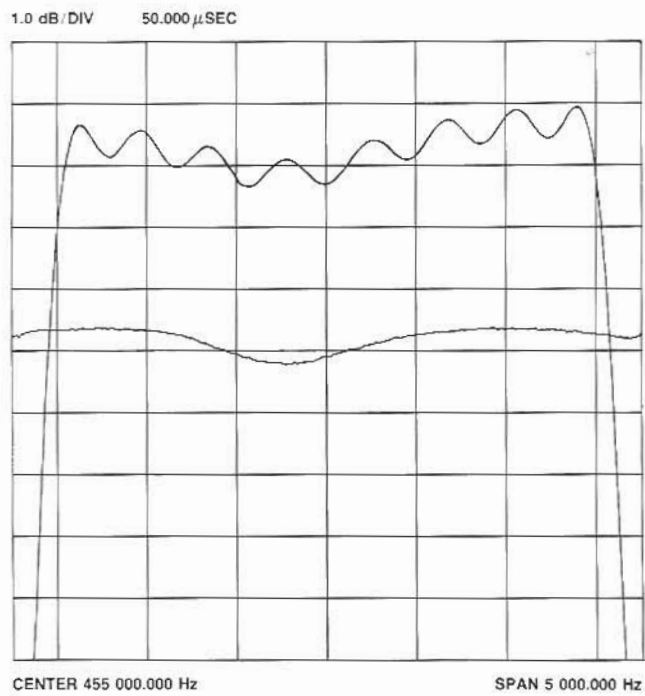

Figure 5. WJ-8711 Typical SSB IF Filter Group Delay & Passband Ripple

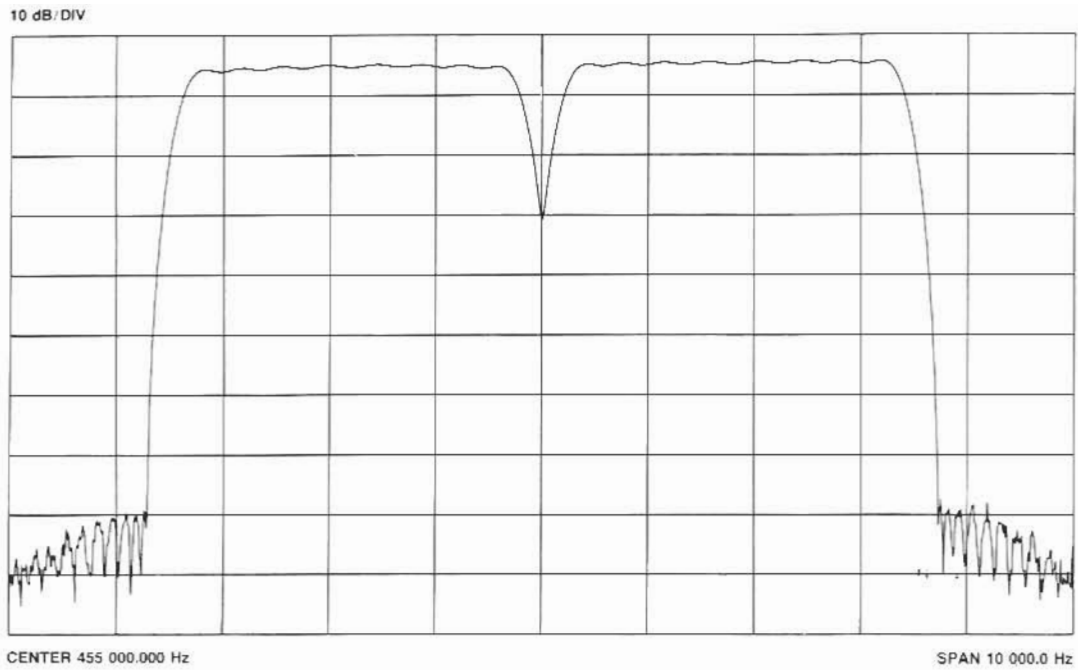

Figure 6. WJ-8711 Typical ISB (USB/LSB) IF Filter Amplitude Response

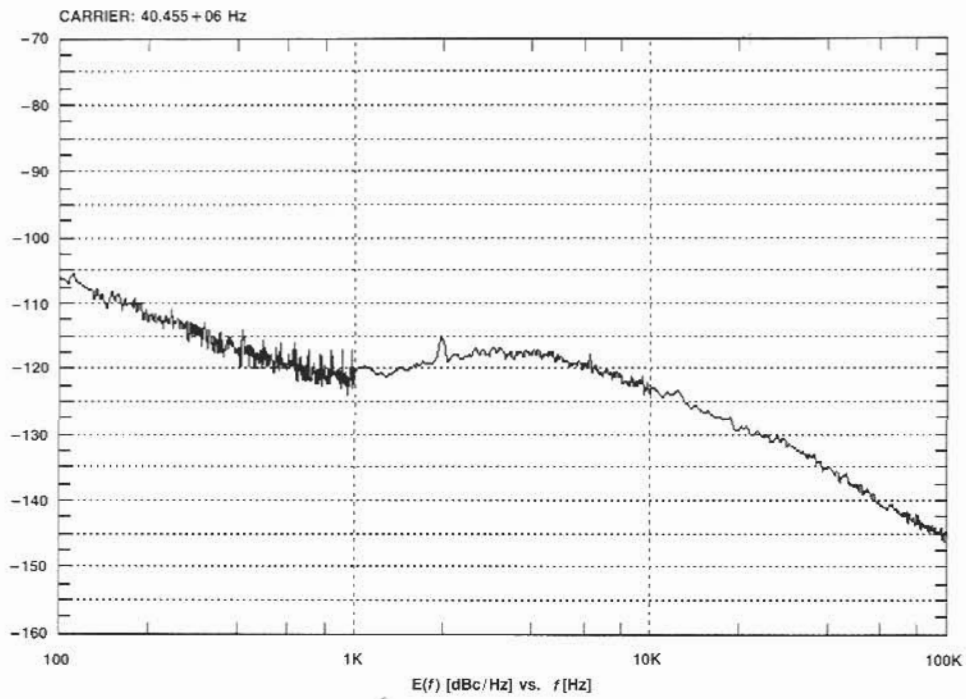

Figure 7. WJ-8711 Typical Phase Noise

Table 3. Options

Nomenclature	Description	Additional Specifications to Basic WJ-8711
Customer-specific options	<ul style="list-style-type: none"> ● additional or alternate IF bandwidths ● additional or alternate detection modes ● alternate I/O interfaces ● customer-specific mechanical configurations 	<ul style="list-style-type: none"> ● contact factory for details
WJ-8711/PRE Suboctave Preselector	<ul style="list-style-type: none"> ● provides filtering of RF input spectrum to reduce broadband signal energy into the receiver into the receiver ● provides 11 separate filter bands, each covering a segment of the overall tuning range ● option can be bypassed if preselection is not desired ● provides automatic receiver-selection of filter band appropriate to tuned frequency 	<ul style="list-style-type: none"> ● enhances 2nd-order inter-modulation performance ● degrades sensitivity/noise figure by 2.5 dB, typical
WJ-8711/SPK Internal Speaker	<ul style="list-style-type: none"> ● provides an 8-ohm, 4-in. (10.16 cm) speaker mounted to top cover ● internally connected to speaker output signal at rear panel ● factory- or field-installable 	
WJ-871Y/REF Frequency Reference	<ul style="list-style-type: none"> ● replaces standard internal reference with one of better stability 	<ul style="list-style-type: none"> ● ± 0.2 PPM over temperature
WJ-871Y/DSO1 Digital Signal Output	<ul style="list-style-type: none"> ● provides digitized time samples of 25-kHz 3rd IF, switched IF and/or audio data 	<ul style="list-style-type: none"> ● contact factory for details & alternate formats